



Technical Reference

MicroTurbine Communications

Introduction

This document presents interconnection information for communications between the Capstone MicroTurbine and associated peripheral equipment.

The document addresses the following communication interconnections:

- Model C30 MicroTurbine UCB Connectors
- Model C60 MicroTurbine UCB Connectors
- Output Relays
- Emergency Stop Inputs
- Fault Inputs
- Serial Communications
- Ethernet I/O Connections
- Wireless Modems

Refer to the following table for a list of reference documents, as required.

Document Part No	Description
410000	Model C30 Electrical Technical Reference
410001	Model C60 Electrical Technical Reference
410003	Capstone Protocol Converter
410024	Capstone PowerServer Technical Reference
410027	Grid Connect (GC) Operation Technical Reference
410028	Stand Alone (SA) Operation Technical Reference
410032	MultiPac Operation Technical Reference
410039	Dual Mode Controller Technical Reference
410040	Modbus Translator Application Guide
410045	Display Panel Menus Technical Reference
440067	Fault Input Wiring in MicroTurbine Applications Work Instructions
512000	Model C30 Fuel Gas Booster Application Notes
512001	Model C60 Fuel Gas Booster Application Notes

Model C30 MicroTurbine UCB Connectors

Figure 1 shows the connector designations on the Model C30 UCB Circuit Board. Connections for Output Relays, Fault Inputs, Emergency Stops, and Serial Communications (RS-232) are identified. Descriptions of these UCB connections are given on the following pages.

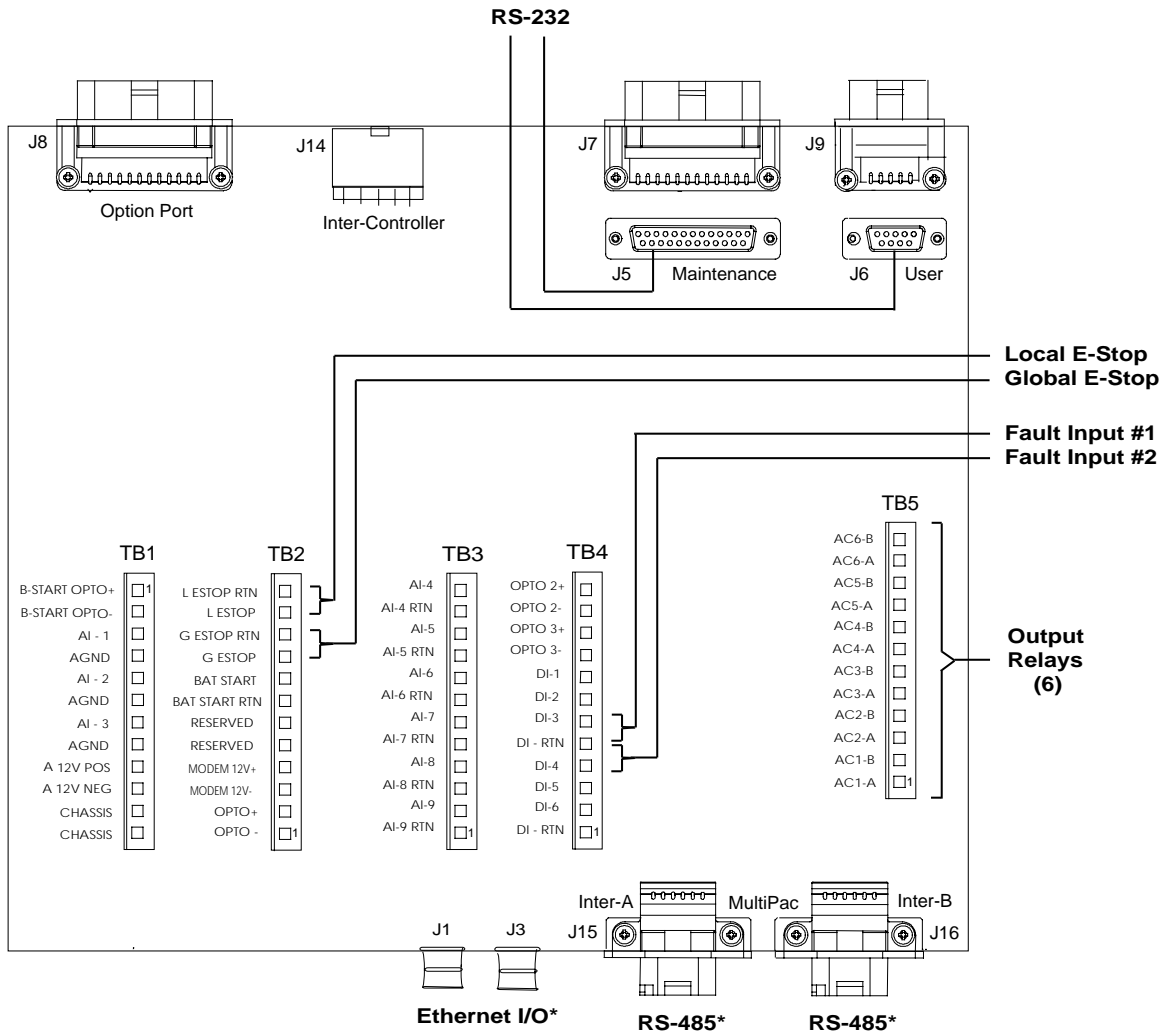

* Refer to MultiPac Operation Technical Reference (410032) and Capstone PowerServer Technical Reference (410024) for Ethernet and RS-485 connection details.

Figure 1. Model C30 UCB Connectors

Model C60 MicroTurbine UCB Connectors

Figure 2 shows the connector designations on the Model C60 UCB Circuit Board. Connections for Output Relays, Fault Inputs, Emergency Stops, and Serial Communications (RS-232) are identified. Descriptions of these UCB connections are given on the following pages.

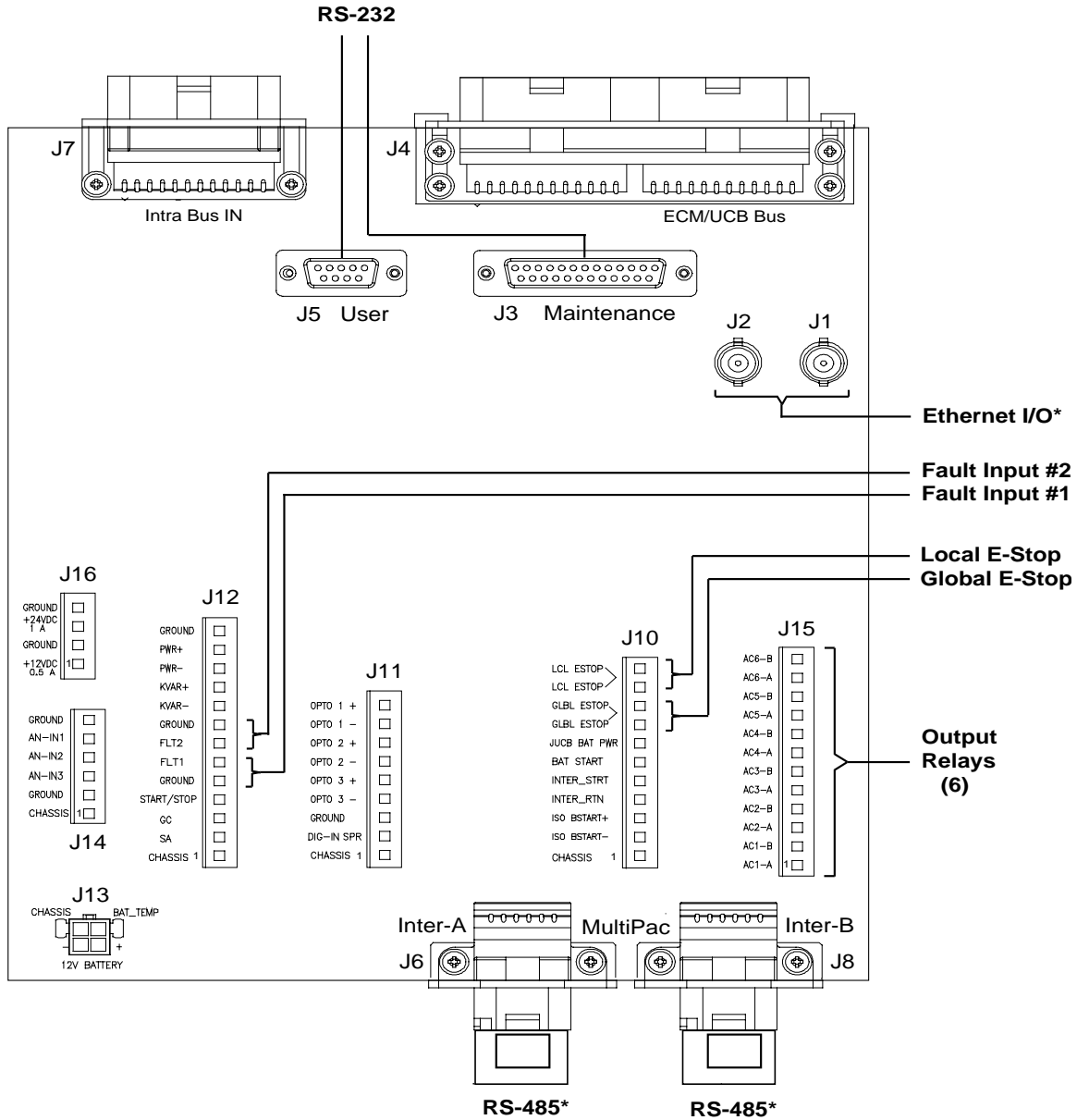

* Refer to MultiPac Operation Technical Reference (410032) and Capstone PowerServer Technical Reference (410024) for Ethernet and RS-485 connection details.

Figure 2. Model C60 UCB Connectors

Output Relays

Six output relays can be user-configured to perform any function listed in the table at bottom of this page. The output relay connections are accessed through terminal pairs on Terminal Block TB5 (C30 UCB) or J15 (C60 UCB) in the UCB Communications Bay. Refer to Figures 1 and 2 for details.

CAUTION	Software must be configured BEFORE making any electrical connections. Failure to do this may cause damage to the MicroTurbine and void the warranty.
----------------	--

These output relays are simple contact closures intended for dry contact circuits. For some applications, the current draw required on the external equipment may exceed the rated current on the UCB relays. In these cases, an interposing relay must be installed.

CAUTION	The coil rating of the interposing relay must not exceed the rated current and voltage on the UCB relays, otherwise, permanent damage to the UCB board may occur.
----------------	---

For auxiliary equipment, i.e. an external compressor requiring only a temporary contact closure, an external timed relay should be used. Electromechanical interposing relays are highly recommended over solid-state relays for electrical isolation.

Refer to the Model C30 Electrical Technical Reference (410000) or Model C60 Electrical Technical Reference (410001) for current and voltage rating of the UCB relays as well as other details.

Relay outputs are commanded to open or close based on Active status and Control Function settings. Note: All relays default to Active Open.

- Active Open (Normally Closed): Relay contact opens when function is true.
- Active Closed (Normally Open): Relay contact closes when function is true.

The user may define each output relay with any function listed in the following table.

Function	Description
Standby	Function is true when the system is in the Standby state.
Run	Function is true when the engine is running or power electronics are enabled.
Contr Closed	Function is true when the Output Contactor is closed.
Fault	When a fault is active, this setting is true when the system active faults create a severity level greater than a warning.
Stand Alone	If the MicroTurbine is in the Stand Alone mode, this function is true.
SA Load	If the MicroTurbine is in the SA mode and in the Load State, this function is true.
Disable	When the system is in the Disable state, this function is true.
Fuel On	This function is true when the electrical fuel shut-off is enabled.
Fuel Purge	Contact will be true for 10 seconds after the main fuel shutoff is closed (for units equipped with liquid fuel only).

Load State	This function is true if the system is in the Load State (GC or SA).
External Load	The relay indicates when the external load may be engaged, i.e., IGBT's are enabled. For example, the relay can be used to run/stop the fuel gas booster in low-pressure systems.
PRT RLY FLT	This function is true when the system active faults have an isolation message of "PRT RLY Fault" (Protective Relay Fault).
ANT-ISL FLT	This function is true when the system active faults have an isolation message of "ANTI-ISL Fault" (Anti-Islanding Fault).
Not Assigned	No software function assigned to this hardware output relay (Default).
CHP Active (If installed)	Signal is active when the system detects MicroTurbine exhaust gas flow.

Emergency Stop Inputs

Two Emergency Stop (E-Stop) inputs are available in the UCB Communications Bay (see Figures 1 and 2). The E-Stop inputs are identified as Local and Global E-Stops. These inputs are simple contact closures intended for dry contact circuits.

- Local E-Stop is used on a single MicroTurbine system. When activated, it will stop this MicroTurbine only.
- Global E-Stop is used on MultiPac Configurations. It is connected to one MicroTurbine in the MultiPac. When activated, it will stop all MicroTurbine systems in the MultiPac.

Refer to the Model C30 Electrical Technical Reference (410000) or Model C60 Electrical Technical Reference (410001) for details.

NOTE	If no external E-Stop device is installed, the E-Stop terminals in the UCB must be jumpered.
-------------	--

CAUTION	Emergency stops increase stress on the system components. Repeated use of the Emergency Stop feature will result in damage to the MicroTurbine. Use only in emergency situations.
----------------	---

Refer to the following table for E-Stop connection details.

MicroTurbine System	E-Stop	UCB Communications Bay
		Terminal Block (Pin Numbers)
Model C30	Global	TB2 (Pins 9 and 10)
	Local	TB2 (Pins 11 and 12)
Model C60	Global	J10 (Pins 8 and 9)
	Local	J10 (Pins 10 and 11)

The E-Stop configurations in a MultiPac system are as follows:

- All Global and Local switches are jumpered (no E-Stop switches installed).
- Global connections at Master, all Local jumpers installed, and subordinate Global connections removed.
- Global at Master, subordinate Global connections removed, and Local E-stop switch at each subordinate.
- All Global switches jumpered, Local E-Stop switch at each subordinate.

Fault Inputs

Two fault inputs are available in the UCB Communications Bay. The inputs are accessed through the Terminal Block TB4 (C30 UCB) or J12 (C60 UCB). Refer to Figures 1 and 2 for fault input connection details.

Fault inputs are simple contact closures intended for dry contact circuits. Refer to the Model C30 Electrical Technical Reference (410000) or Model C60 Electrical Technical Reference (410001) for details.

Refer to Fault Input Wiring in MicroTurbine Applications Work Instructions (440067) for fault input wiring details.

The following settings are available for Fault Inputs:

- Enable/Disable (On/Off) - If On, control detects a fault input into the system from an external fault source.
- Fault Level - defines the system severity level of this fault source.
- Time (sec) - adjusts the debounce time for fault input detection from an external device, i.e., how much time the fault is detected for before the fault is latched in the system.
- Polarity— selects Normally Closed (Active Open) or Normally Open (Active Closed) logic polarity.

Serial Communications

A PC or PLC device may be connected to the UCB for monitoring, controlling, or troubleshooting a MicroTurbine system. The MicroTurbine communicates via RS-232 protocols using a null modem cable with hardware handshaking. A DB9 connector (User Port) and a DB25 connector (Maintenance Port) are available. If devices are connected to both ports, the port accessed at the higher severity level has priority for command of the system. If both are at the same password level, the Maintenance Port has priority.

DB9 Connector (User Port)

A 9-pin RS-232 connector is used for User Port and is identified as J6 on C30 UCB (see Figure 1) or J5 on C60 UCB (see Figure 2). Pin designations are as follows:

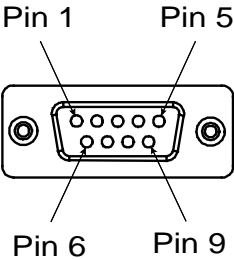
Pin No.	Signal	Description	RS-232 Connector (DB9)
1	DCD	Data Carrier Detect	
2	RXD	Receive Data	
3	TXD	Transmit Data	
4	DTR	Data Terminal Ready	
5	SG	Signal Ground	
6	DSR	Data Set Ready	
7	RTS	Request to Send	
8	CTS	Clear To Send	
9	RI	Ring Indicator	

DB25 Connector (Maintenance Port)

A 25-pin RS-232 connector is used for Maintenance Port and is identified as J5 on C30 UCB (see Figure 1) or J3 on C60 UCB (see Figure 2). Pin designations are as follows:

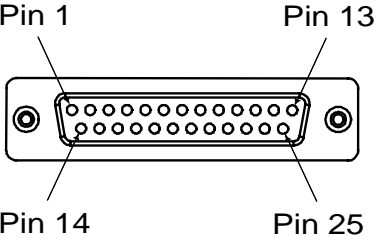
Pin No.	Signal	Description	RS-232 Connector (DB25)
2	TXD	Transmit Data	
3	RXD	Receive Data	
4	RTS	Request to Send	
5	CTS	Clear To Send	
6	DSR	Data Set Ready	
7	SG	Signal Ground	
8	DCD	Data Carrier Detect	
20	DTR	Data Terminal Ready	
22	RI	Ring Indicator	

Null Modem (or Modem Eliminator) Cable

A null modem cable is used for connecting two computers together without a modem. It is a RS-232 cable that interchanges conductors 2 and 3. It is also known as a modem eliminator. Wiring connections for null modem cables with DB9 connector (see Figure 3) and DB25 connector (see Figure 4) are as follows:

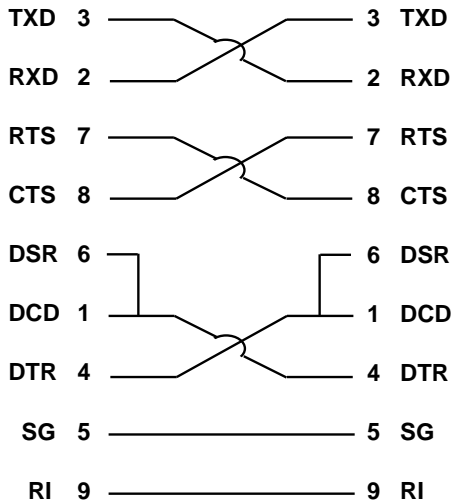

Figure 3. DB9 Null Modem Cable

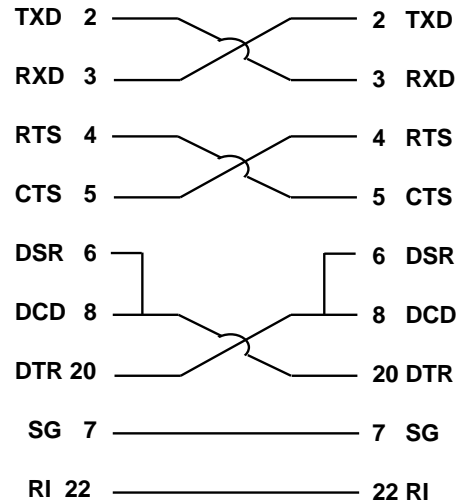

Figure 4. DB25 Null Modem Cable

Ethernet I/O Connections

The Ethernet connectors are identified as J1 and J3 on the C30 UCB (see Figure 1), and as J1 and J2 on the C60 UCB (see Figure 2). These connectors are used for MultiPac communications. Refer to MultiPac Operation Technical Reference (410032) and Capstone PowerServer Technical Reference (410024) for Ethernet connection details.

Cable Type

The cable type required for Ethernet connection is RG-58A/U (coaxial, 50-Ohm impedance). Recommended cable type is Belden, Part Number 9907 or equivalent.

Ethernet Requirements

The Ethernet adheres to the requirements set forth in IEEE 802.3 Carrier Sense Multiple Access with Collision Detection (CSMA/CD) Access Method and Physical Layer Specifications. The basic requirements include the following:

Maximum Segment Length

The maximum segment length of a thin wire 10B2 cable is 185 meters or 607 feet. The designation "10BASE-2" stands for 10 Mbps/Baseband/200 meters. The 200m length is rounded up from 185m. For longer segments, a fiber optic repeater can be used.

Minimum Segment Length

The minimum segment length of thin wire 10B2 cable is 0.5 meters or 1.64 feet.

MAU Requirements (Connections)

Up to 30 connections (Medium Attachment Units or MAUs) are allowed per Ethernet segment. For larger LAN's, repeater hubs are required. Each repeater connection requires a MAU that must be counted toward the total of 30 MAU connections per segment.

Wireless Modems

For remote MicroTurbine installations where no landline telephone service is available, a radio or cellular modem is highly recommended for monitoring and troubleshooting the MicroTurbine system. Several third-party cellular and radio modems have been successfully used with the Capstone MicroTurbines.

Connections to Third-Party Modems

The following paragraphs present connection details between the MicroTurbine and the third-party modems.

Modem Power

The modem can be powered from the power supply available in the UCB box (see Figure 1, TB1 and TB2, and Figure 2, J16). Make sure the current rating of the modem does not exceed that of the power supply.

Communications Cable

The modem can be connected to the User Port or Maintenance Port of the MicroTurbine. Typically, it is connected to the Maintenance Port. A straight-through serial cable is required in most cases for data connection between the modem and the MicroTurbine. See the *Serial Communications* section for the connector pin assignments.

Modem and MicroTurbine Settings

The MicroTurbine port speed setting must be set to the same speed as the modem.

The default hardware configuration for the User and Maintenance Ports is 57,600 bits per second (maximum speed), 8-bit word length, no parity, one stop bit, and hardware handshake for flow control. It is recommended to use the highest speed available on the modem, not exceeding the maximum speed of the MicroTurbine port.

Upon initialization, the MicroTurbine sends an AT&F command to restore the factory settings of the modem. If this affects the desired settings on the modem, the modem can be powered on by a delay timer of at least two minutes after the MicroTurbine wakes up. In this case, the modem should be configured independently through a HyperTerminal session or using the modem's PC software.

Some telemetry modems have different modes for data packet transmission. For the MicroTurbine to communicate properly, the transmitted data packets should never be split. For example, the Integra-H modem flow control should be set to DOX mode, by which the data packets are kept together during transmission.

Resources for Wireless Modems

A list of recommended modem vendors and model numbers that may be suitable for installation at your location is presented below. Contact your local cellular telephone service companies for a list of cell modems with coverage in your area. For telemetry and radio modems, be aware of local and FCC regulations, as well as permits required for using air radio frequencies. The usage of some radio frequencies may require special licenses.

NOTE	Cellular modem models and brands vary greatly depending on the service offered in your area. Contact your local telephone companies for the service and models available.
-------------	---

Cellular Modems:

Manufacturer: Airlink
Website: www.airlink.com
Model: Airlink Raven II CDPD

Manufacturer: Motorola
Website: www.motorola.com
Model: 781GWTY164Y

Radio/Telemetry Modems:

Manufacturer: Data Radio
Website: www.dataradio.com
Model: Integra H

Manufacturer: Locus Inc.
Website: www.locusinc.com
Model: OS2400-485

Capstone Technical Support

If you have additional questions, please contact:

Capstone Technical Support Telephone: (818) 407-3600 Facsimile: (818) 734-1080 Toll Free Telephone: (877) 282-8966 E-mail: service@capstoneturbine.com	Capstone Technical Support (Japan) Telephone: (818) 407-3700 Facsimile: (818) 734-1080 E-mail: servicejapan@capstoneturbine.com
--	---