



Technical Reference

Horizontal Fuel Gas Booster - Model C60 MicroTurbine

Introduction

This document presents installation information for the Copeland Horizontal Fuel Gas Booster, hereafter referred to as a Fuel Gas Booster or FGB, and its integration with the Capstone Model C60 MicroTurbine. The FGB is a variable-speed drive device that serves to boost the inlet supply pressure of low-pressure Natural Gas.

The Model C60 MicroTurbine inlet operating pressure requirement is: 517 to 552 kPa gauge (75 to 80 psig) for high-pressure natural gas. Supply pressures that fall below the lower limit require the FGB installation.

The FGB can operate on AC voltage from the grid (P/N 518752-1XX) or DC voltage from the Model C60 MicroTurbine (P/N 516592-1XX).

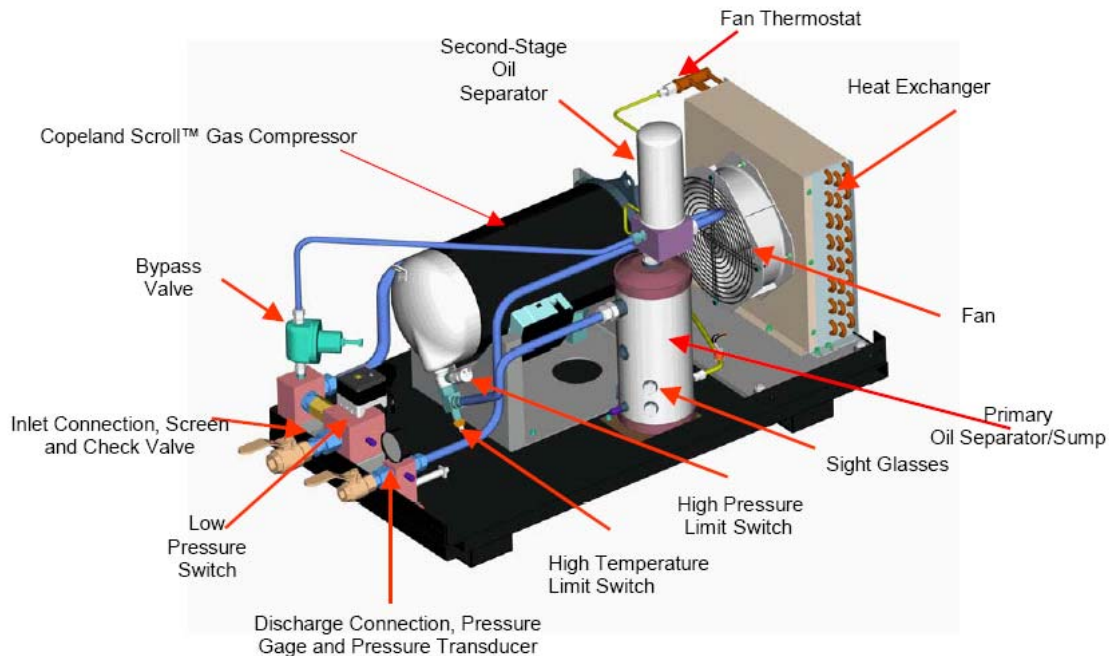

Figure 1. Copeland Horizontal Fuel Gas Booster (Cover Removed)

MicroTurbine Supply Pressure Requirements

Minimum required FGB inlet pressure values presented above **MUST** be maintained under all operating conditions. Inlet pressures below these values will cause the system to shut down.

Capstone recommends that the user install a suitable pressure gauge before the inlet of the Fuel Gas Booster to verify the minimum required inlet pressure values are satisfied during system operation.

Number of MicroTurbines	Operating Mode	Minimum Required Inlet Pressure
1	Grid Connect	0.2 psig
2	Grid Connect	5.0 psig
1	Stand Alone	0.2 psig
2	Stand Alone	8.0 psig

The FGB DC-powered compressor Kit (517202-1xx) contains a pressure regulator, gauge, manual shutoff valve and gas filter, which must be installed between the FGB outlet and the MicroTurbine inlet. The kit includes the following components:

517202-100 DC Compressor Kit

516592-1xx Fuel Gas Compressor, Horizontal Scroll/DC - Copeland

512573-0xx Cable, DC Power, Copeland Compressor – C60

512574-0xx Cable, DC Signal, Copeland Compressor – C60

507849-1xx Fuel System, High Pressure Option Kit

There are three other compressor kits that may be used for (AC) installations as well:

518611-100 Fuel Option Kit

518614-001 Equimeter Regulator

518620-001 3/4" Ball Valve

518612-100 Gas Compressor Std Option

518615-001 VanAir 3/4" Filter

518620-001 3/4" Ball Valve

518613-100 Fuel Option Kit (NY)

518616-001 Parker 3/4" Filter

518620-001 3/4" Ball Valve

Contact Capstone Technical Support for kit availability and requirements.

Operating Fluid Pressures

The FGB is designed to deliver the specified flow within the range of pressures listed below at the ranges of temperatures listed:

Condition	Temperature
Inlet Pressure Range	0.2 to 10 psig
Outlet Pressure Range	85 ± 5 psig
Inlet Temperature Range	-4 to 122 °F
Maximum Discharge Temperature	180 °F

Refer to the Fuel Requirements Technical Reference 410002-001 for gaseous heating values, specific gravity and other parameters related to the fuel source.

Operating Characteristics

Figure 2 shows the relationship between natural gas fuel flow and power draw.

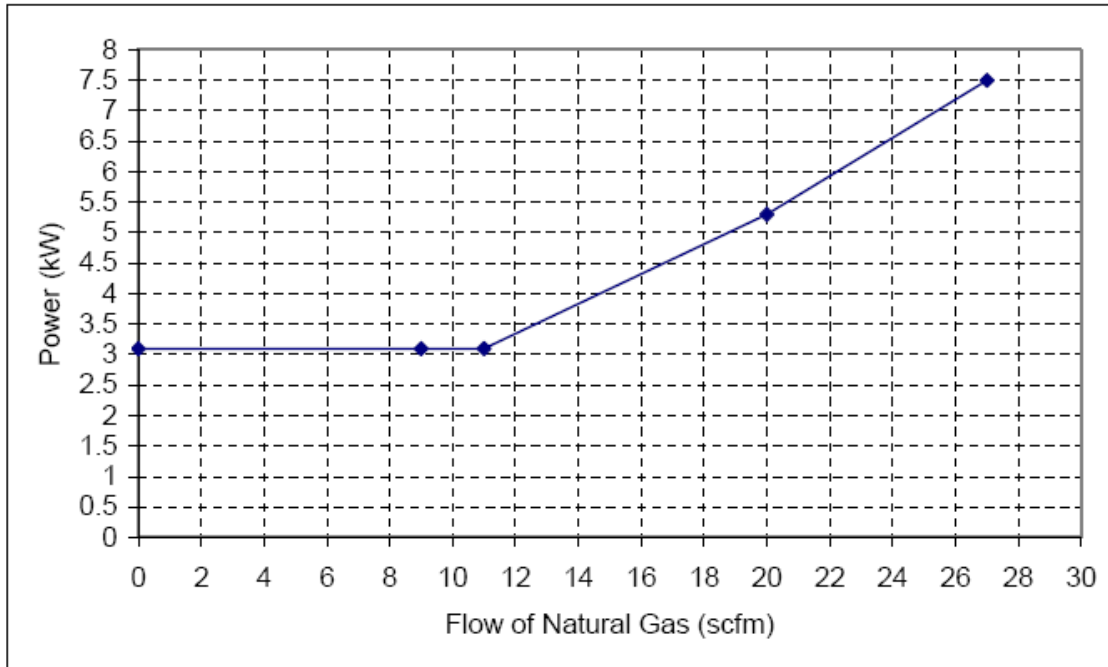

Figure 2. Fuel Flow Characteristics

Physical Characteristics

The FGB utilizes terminal blocks for both power and communication signals, and female 3/4-inch NPT connections on both fuel inlet and outlet ports. FGB weight will not exceed 500 pounds (227 kg).

Operating Environment

The FGB is capable of operating in an environment as follows:

- Temperature Range:

Temperature	FGB State
14° to 122°F (-10° to 50° C)	No FGB Power
-4° to 122°F (-20° to 50° C)	FGB has continuous power, but not running
-20° to 122° (-29° to 50° C)	FGB operating continuously

NOTE: Do not apply power to FGB if temperature falls below 14° F (-10° C).

- Pressure Range: 8.7 to 15 psia
- Relative Humidity: 95% non-condensing (in surrounding ambient air)

Storage Environment

The FGB is capable of being stored in an ambient environment as follows:

- Storage Environment: -4° to 122°F
- Pressure: 1.7 to 15 psia (Absolute)

DC Electrical Characteristics

The FGB (DC configuration) complies with the following electrical requirements:

Parameter	Requirement
DC Input Voltage, continuous	760 ± 5%

AC Electrical Characteristics

The FGB (AC configuration) complies with the following electrical requirements:

Parameter	Requirement
AC Voltage	400-480 VAC 50/60 Hz

Installation Requirements

Separation Distance

The FGB must be set level prior to operation and placed at least 28 inches from the side of the MicroTurbine enclosure to provide adequate service clearance. The control and high power interface cable lengths between the MicroTurbine and FGB should not exceed six meters (20 feet).

Inlet Fuel Supply

There must be an adequate supply of gaseous fuel to prevent low inlet pressure and FGB faults. In addition, the fuel supply must be sized to maintain minimum inlet pressure under all operating conditions. Failure to maintain an adequate supply of fuel can result in low inlet pressure faults at start-up (see the "Introduction" section for details).

Low Discharge Pressure

The FGB discharge pressure is typically 586 kPa gauge (85 psig) and varies depending on operating conditions and demand. Operation at low discharge pressures may cause the discharge line to be contaminated with compressor oil. As a result, never operate the FGB unless the outlet fuel lines are properly connected to the MicroTurbine and any bleed valves to low pressure (such as to atmosphere) are closed.

Sequence of Procedural Steps

The following bulleted steps provide an overview of the installation process. These steps must be performed in the sequence listed to prevent damage to the MicroTurbine and subsequently void the warranty.

- Attach associated FGB pipe connections to the MicroTurbine.
- Apply power to the MicroTurbine.
- Program the UCB Output Relays (see “Software Setup”).
- Power down the MicroTurbine.
- Perform control interface electrical connections (see “Electrical Connections”).
- Perform high-voltage connections (see “Electrical Connections”).
- Perform fuel connections (see “Fuel Connections”).
- Adjust the pressure regulator (if necessary).
- Start the MicroTurbine.

Installation Procedure

Software Setup

Program the MicroTurbine software before any electrical connections to the Fuel Gas Booster as follows:

1. Ensure that there are no electrical connections between the MicroTurbine and the Fuel Gas Booster.
2. Power up the MicroTurbine.
3. Program the output relays as follows:

NOTE	The Capstone software must be set up to treat the Fuel Gas Booster as an External Auxiliary Load. Any of the output relays may be configured to perform this function; however, the specified wiring connections demonstrate the use of Relay #1.
-------------	---

Using the control panel on the MicroTurbine, proceed as follows:

- a. On the UCB Relays menu, Relay #1 submenu, set EXT LOAD to ACTIVE CLOSED.
 - b. On the System Settings menu, Fault Input #1 submenu, set Fault Input #1 to ENABLE (Fault signal from FGB). On Fault Input #1 submenu, set SSL to 3 and time to 12 seconds.
4. Power down the MicroTurbine.

Electrical Connections

NOTE	Fuel Connections are described on the following pages, and should only be made after the Electrical Connections are all in place.
-------------	---

When installing the Fuel Gas Booster, the electrical connections between the Fuel Gas Booster and the MicroTurbine must be performed in the following sequence to avoid failure and prevent voiding of the warranty. Installation, operation and maintenance shall be performed only by a licensed electrical contractor, in accordance with NEC/NFPA 70 and local/federal electrical codes.

Control Interface

CAUTION	The power and signal wires must be installed in separate conduit.
----------------	---

1. Prepare the control interface electrical connections as follows:
 - a. The signal wiring between the Fuel Gas Booster and the Model C60 must be shielded, 20 AWG 2-pair. All of the signal wiring must be enclosed within a 1/2-inch, weatherproof flexible steel conduit.
 - b. Always ground the electrical cable shield to the chassis on the MicroTurbine side.

- c. Voltage suppressors must be installed over the run/start signal lines (AC1-B and AC1-A of connector J15) and on the fault signal lines (Ground and FLT1 of J12). Voltage suppressors are not required on the newer Model C60 MicroTurbine systems using JUCB, Part Number 511714-1XX.
 - d. The switching relays on the JUCB board **MUST BE** configured correctly, or equipment will be damaged (see the Software Setup section).
 - e. Two sets of electrical wires from the Fuel Gas Booster must be connected to the JUCB on the MicroTurbine system:
 1. The Fuel Gas Booster Run Switch electrical leadwires must be connected to Pin 1 and to Pin 2 of connector J15. The pins are labeled AC1-A and AC1-B. Wrap these leadwires around a torroid suppressor at least three times.
 2. The Fuel Gas Booster Fault Status electrical leadwires must be connected to Pin 6 and Pin 5 (or 8) of connector J12. The pins are labeled FLT1 and GROUND. Wrap these leadwires around a torroid suppressor at least three times.
2. If the FGB is compressing gas for more than one MicroTurbine, the RUN signal from the MicroTurbines can be connected in parallel to the RUN terminals of the FGB. In this configuration, if any of the MicroTurbines is started, a RUN signal will be applied to the FGB. Note that the RUN signal, terminals 1 and 2 of multiple FGBs must not be connected together.
 3. Connect the Fuel Gas Booster control terminals to the correctly programmed output relays.

DC Systems

4. Prepare the high power electrical interface connections as follows (reference Figure 3):
 - a. The high power electrical leadwires must be 14 AWG, 600V, Red (+), Black (-), and Green/Yellow (GND). The wiring **MUST** be enclosed within a 1/2-inch, weatherproof, flexible steel conduit.
 - b. The Fuel Gas Booster high power electrical leads are to be connected to the DC bus on the controller. The high power electrical leads should be connected at the rear of the unit as shown in Figure 3.

WARNING	When connecting the Fuel Gas Booster DC Bus high power electrical leads, ALWAYS connect the FGB side FIRST, and then connect the MicroTurbine side.
----------------	---

CAUTION	BE SURE to correctly connect the polarity on the DC Bus. Incorrectly connecting the DC Bus will cause damage to the Fuel Gas Booster.
----------------	---

5. Connect the Fuel Gas Booster high voltage terminals to the MicroTurbine DC bus.
6. Connect the metallic conduit to the chassis at both the MicroTurbine and the Fuel Gas Booster.
7. Power up the MicroTurbine

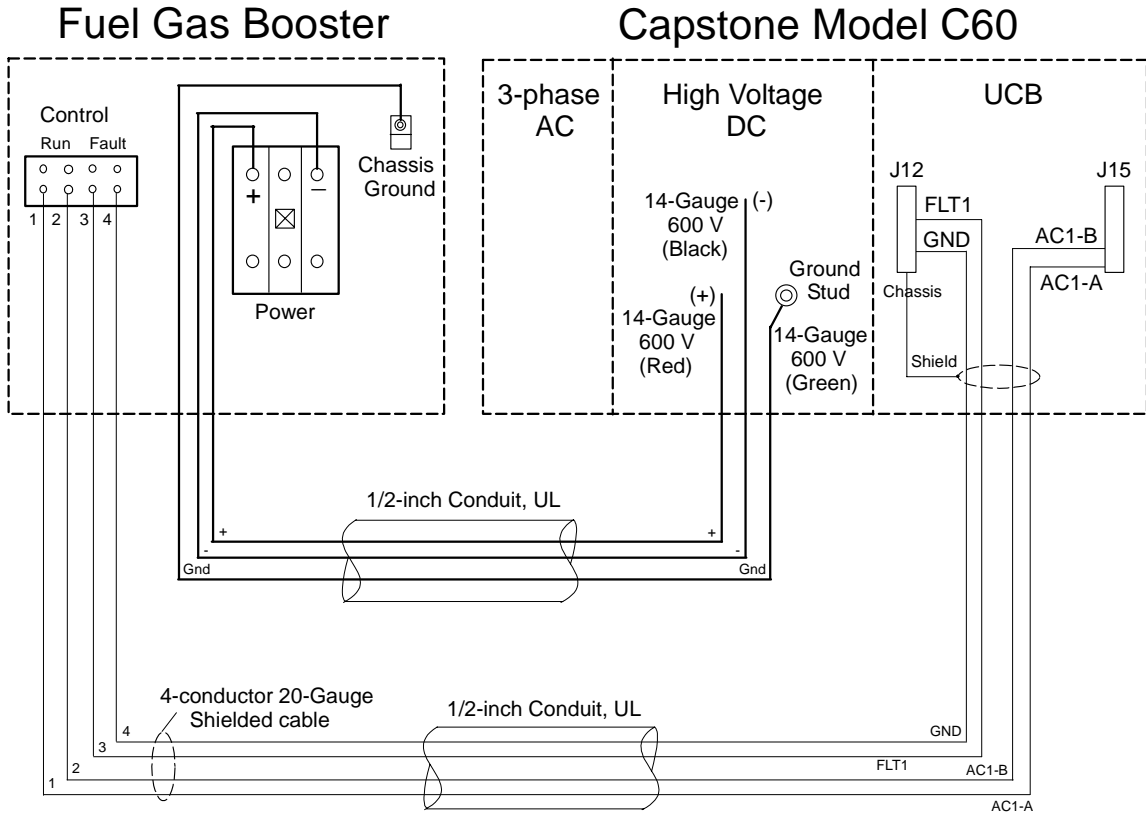

Note:
 Refer to text for electrical connection details
 and software setup instructions.

Wiring Connections

Fuel Gas Booster	C60 JUCB
1	J15, AC1-A
2	J15, AC1-B
3	J12, FLT1
4	J12, Ground
Shield	J12, Chassis

Figure 3. DC System Wiring Diagram

AC Systems

4. Prepare the 3-phase electrical interface connections as follows (see Figure 4):
5. Connect the metallic conduit to the chassis at both the MicroTurbine and the Fuel Gas Booster.
6. A fused disconnect switch can be connected from the Grid to the FGB power supply. See Figure 5 for installation.
7. Power up the MicroTurbine.

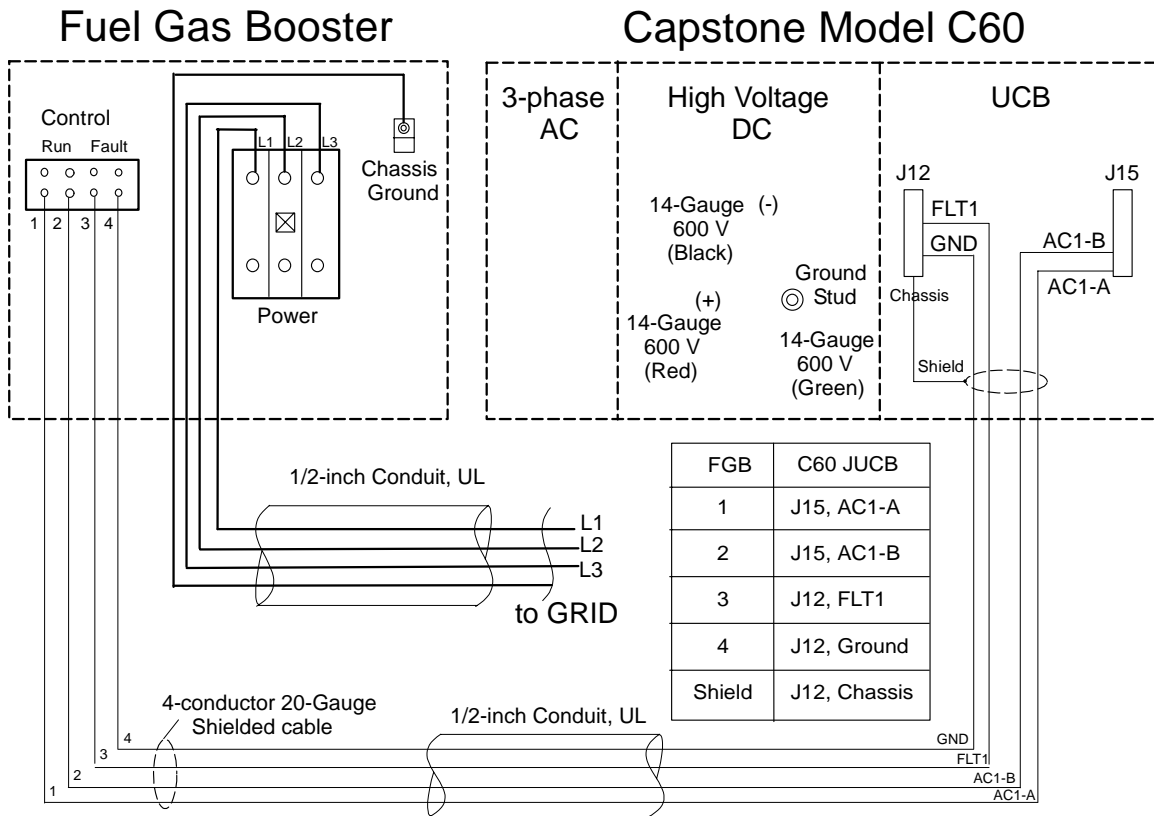

Note: Refer to text for electrical connection details and software setup instructions.

Figure 4. AC System Wiring Diagram

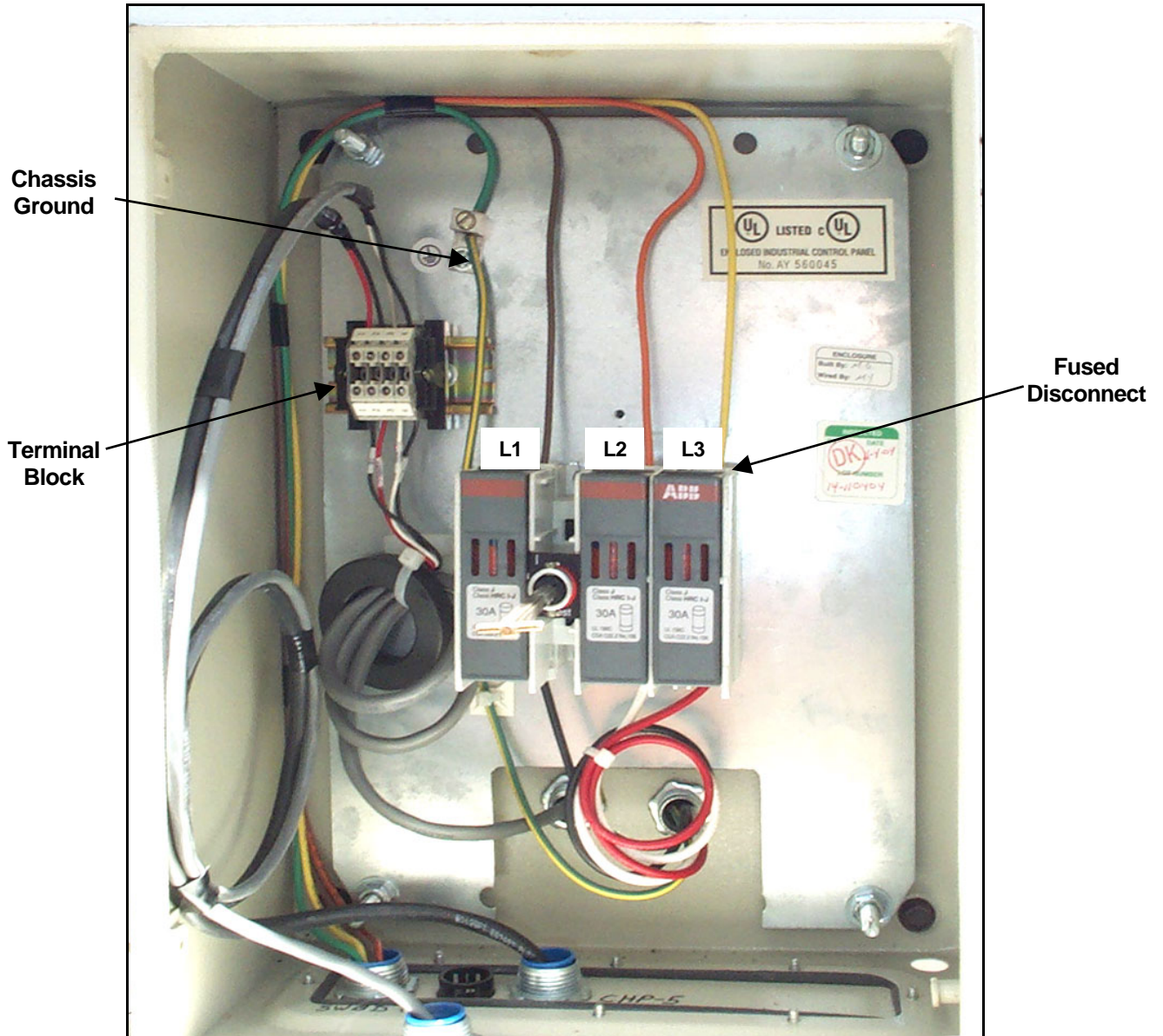
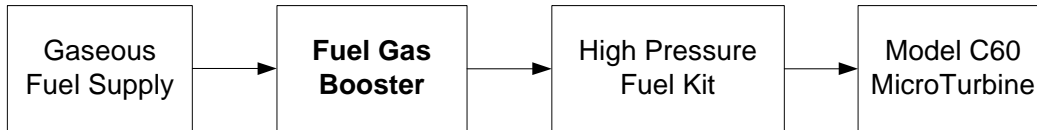

Figure 5. FGB Installation – AC System

Fuel Connections

WARNING	Non-compliance with local and Federal fuel safety codes when performing maintenance operations may result in injury or death.
----------------	---

MicroTurbine fuel supply installation shall be in accordance with NFPA 37 and local and Federal codes. Fuel-related pipe installation shall be performed by a licensed contractor (and qualified pipe fitter) in accordance with local codes and regulations. Refer to the MicroTurbine Fuel Requirements Technical Reference (410002) to confirm that the selected fuel meets Capstone-approved content requirements. A fuel connection block diagram is shown below.



Prepare the fuel system interconnections as follows:

1. The Fuel Gas Booster inlet connection is 1-inch NPT and the outlet connection is 3/4-inch NPT. 3/4-inch flanged for all New York applications.

WARNING	<p>Always adhere to the Fuel Safety Precautions listed below when performing fuel maintenance operations:</p> <ul style="list-style-type: none">• Keep flames, cigarettes, pilot lights, and electrical arc-producing equipment, plus all other sources of ignition well away from areas where natural gas fumes are present.• Keep all sources of ignition away from areas sharing ventilation.• Keep natural gas lines secure, free of leaks, and separated or shielded from all electrical wiring.• If you smell natural gas: (1) Immediately cease operation of the equipment. (2) Close the fuel isolation valve. (3) Call a qualified professional to locate and repair the source of the leak.
----------------	--

2. NFPA 37 and local codes should be used as a guide for installing the MicroTurbine fuel supply. The pressure regulator must be sized to avoid flow restriction and set to regulate pressure at the package inlet.
3. The following fuel related items must be installed prior to final commissioning:
 - Piping from the gas supply to the MicroTurbine.
 - Manual fuel isolation valve for the MicroTurbine and FGB system.
 - Main fuel gas filter and pressure regulator.
 - Purge valve to flush out the gas supply line.

4. Prior to operating the MicroTurbine, check all fuel lines as follows:
 - a. Check and verify that all fuel gas connections are tight and secure.
 - b. Open the main manual fuel shut-off.
 - c. Check and verify that all fuel gas connections are tight and secure.
 - d. Using a gas detector or a non-flammable leak detecting fluid, perform a leak check of all gas pressure lines and fittings. No fuel leaks of any kind are allowed.
 - e. Close the main manual fuel shut-off.
7. Follow additional steps listed in Commissioning Checklist (460006).

Installation Validation

Once installed, an initial operation of the Model C60 with the Fuel Gas Booster combination is required to validate the installation. Refer to the Fuel Gas Booster Owner's manual for detail information and for Commissioning instructions.

Scheduled Maintenance

Perform scheduled maintenance in accordance with supplier requirements listed in FGB manufacturer's documentation and Capstone documentation. Each site should have at least one FGB Installation and Maintenance Tool Kit plus one Maintenance Parts Kit. Refer to the Fuel Gas Booster's Owner's Manual for additional information.

Filtration Maintenance

Filtration including fuel gas, FGB cooling air and lubrication systems shall allow normal operation and only require maintenance at 8000 hour intervals.

Lubrication System Maintenance

The oil capacity and consumption shall be such that oil replenishment, if required, is at minimum levels of 8000 hours of operation.

Capstone Documentation

The following table lists applicable Capstone documentation.

Document	Description
410002	Capstone MicroTurbine Fuel Requirements Technical Reference
460006	Commissioning Checklist – Capstone MicroTurbine

Capstone Customer Service

If you have additional questions, please contact:

Capstone Applications Support

Toll Free Telephone: (877) 716-2929
Service Telephone: (818) 407-3692
Facsimile: (818) 734-1092
E-mail: applications@capstoneturbine.com

Capstone Technical Support

Toll Free Telephone: (877) 282-8966
Service Telephone: (818) 407-3600
Facsimile: (818) 734-1080
E-mail: service@capstoneturbine.com

Capstone Technical Support - Japan

Service Telephone: (818) 407-3700
Facsimile: (818) 734-1080
E-mail: servicejapan@capstoneturbine.com