

# Technical Reference

## Protective Relay Functions for Capstone MicroTurbines

This document presents information for the Capstone Turbine Corporation® Protective Relay.

### Introduction

The Capstone MicroTurbine™ generator may be connected in parallel to a utility grid to power local grid connected loads (Figure 1). When installed in this fashion, the MicroTurbine operates in an inherently safe manner in that power generated by the MicroTurbine is supplied to these loads only when the utility grid voltage is present.

During utility grid voltage interruptions, the MicroTurbine senses the loss of utility voltage and disconnects from the grid and the local loads. When the utility grid voltage returns to within its specified limits, the MicroTurbine may be programmed to restart and supply power to the connected loads.

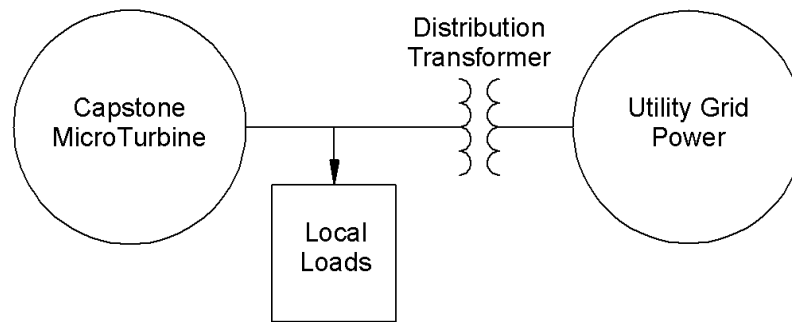

Figure 1. Capstone MicroTurbine-Grid Connect System Configuration

The Capstone MicroTurbine systems include intelligent power controllers, which operate as self-commutated, current controlled inverters when connected to a utility grid. The power controller is called a Digital Power Controller (DPC) in the Model C30, or Engine Control Module (ECM) and Load Control Module (LCM) in the Model C60 MicroTurbine.

**NOTE**

To maintain consistency and ease of reference to both the Model C30 and Model C60 MicroTurbines, the DPC (in Model C30) and ECM and LCM (in Model C60) will be referred to as the Power Controller throughout this document.

Utilities commonly require that protective relaying devices be installed with generators connected to their grid. The primary purpose of these protective relaying devices is to ensure that the local generator will not energize utility wires de-energized by the utility.

Historically, these protective relaying devices have been dedicated relays or dedicated solid-state power analyzers that provide control signals to disconnecting relays.

The Capstone MicroTurbine has protective relaying functions built into the Power Controller. This document gives an overview of the Power Controller and describes the protective relaying functions. Protective functions defined for the programmable limits are stored in nonvolatile memory in the power controller and hence any changes remain set even after an interruption in utility power.

Detailed information on the Capstone MicroTurbine systems may be found in the MicroTurbine User's Manual (400000).

## **Power Controller Operation Overview**

Figure 2 shows a block diagram of the MicroTurbine installed in *Grid Connect* mode.

A gas turbine engine integral with a high-speed permanent magnet generator is called the *turbogenerator*.

The Power Controller converts high frequency power from the turbogenerator into 50/60 cycle AC power. The Power Controller also regulates fuel supply to the turbogenerator.

During the startup sequence, power flow through the Power Controller is reversed. Grid power is used to motor the turbogenerator. When power is available from the turbogenerator, the Power Controller converts the generator output to 3-phase 50/60 HZ power synchronized with the utility grid.

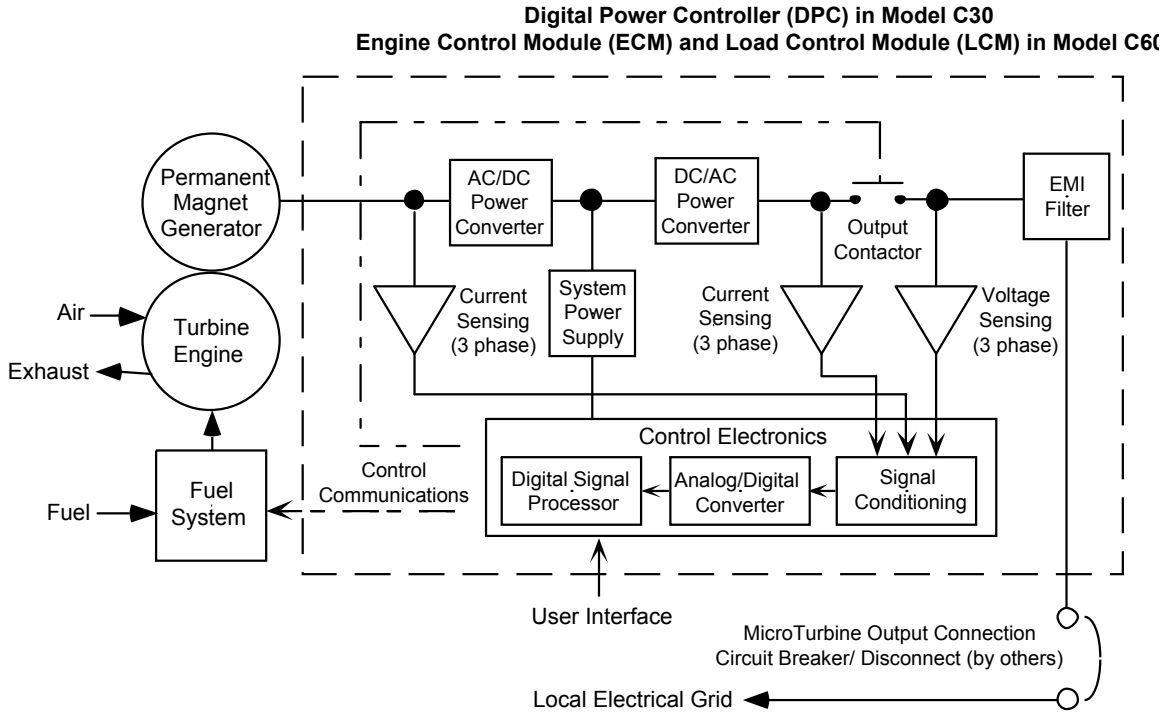

Note: It is essential for safe operation and service that a current limiting disconnect device be installed between the Power Controller and the utility grid. Local electric codes will almost always require such a disconnect. The added protection of this disconnect device is not considered here.

Figure 2. Capstone MicroTurbine – Functional Block Diagram

## Power Controller Components and Function

The major components of the Power Controller are two 3-phase power converters, power-conditioning equipment, a microprocessor based system controller, and an auxiliary power supply for the controls. The operation and power conversion functions of the Capstone MicroTurbine™ are conducted and controlled by the Power Controller.

The output power requirements for voltage and current including fault limits can be found in the Model C30 Electrical (410000) and Model C60 Electrical (410001) Technical Reference documents. Voltage and current harmonics of the power controller conform to IEEE 519-1992<sup>1</sup> at rated power.

## Other Power Controller functions include:

- Supervisory control of the MicroTurbine operation (including protective relaying functions)

<sup>1</sup> IEEE 519-1992. IEEE Recommended Practices and Requirements for Harmonic Control in Electrical Power Systems. Institute of Electrical and Electronics Engineers, New York.

- ❑ MicroTurbine safety supervision
- ❑ Fuel flow control and combustion management
- ❑ Internal communications with auxiliaries
- ❑ External communications with the user and with other equipment

## Grid Connect Features

When connected to an energized grid, the Power Controller inverter injects current into the grid. Under these conditions, the Power Controller follows the prevailing grid voltage and frequency.

### NOTE

Due to line and/or transformer impedance, the current produced by the Capstone MicroTurbine may change the voltage at the point of connection.

Power delivered by the Power Controller is proportional to the product of current flow and the line voltage. The Power Controller will deliver constant power, subject to the Power Controller hardware current limits, until the user initiates a control change or one of the protective relay functions described below becomes active.

The algorithms used to operate the Power Controller provide excellent protection against islanding<sup>2</sup> of the Power Controller in the absence of utility-supplied grid voltage. Near short or near open islands are detected within a few cycles through loss of current control.

Islands whose loads are more closely matched to the Power Controller output will be detected by the Rate of Change of Frequency and built-in active Anti-Islanding protection.

## Protective Functions

The protective functions included in the Power Controller are described in this section. Voltage sensing and signal processing are illustrated in Figure 2. The Protective Function designator numbers correspond to those published by IEEE<sup>3</sup>.

### NOTE

All protective function measurements and calculations are based on the Line-to-Neutral voltage values. However, for convenience, all protective function settings are entered as equivalent Line-to-Line voltage values.

## Under Voltage (Protective Function 27)

### Primary Under Voltage Trip

The Primary Under Voltage is adjustable from 360  $V_{L-L}$  up to the Over Voltage set point. (Default = 428 V). The time period is adjustable from 0.3 to 10.00 seconds in 0.01 second increments. (Default = 1.90 seconds)

<sup>2</sup> Islanding: "A condition in which a portion of the utility system that contains both load and operating generation, which is not under utility control, remains energized while isolated from the remainder of the utility system.

<sup>3</sup> IEEE C37.90-1989. IEEE Standard relays and Relay Systems Associated with Electric Power Apparatus. Institute of Electrical and Electronics Engineers, New York.

The UL1741 requirement for this function is:

- *The device should cease to energize the output within 2 seconds when any of the phase voltages is lower than  $244 V_{L-N}$  while the other phase voltages remain at  $277 V_{L-N}$*

As shipped, each Power Controller is tested to verify that it meets the UL1741 requirement to initiate a Grid Fault Shutdown, if any phase-to-neutral voltage sags to less than  $264 V_{L-N}$  for duration greater than 2.0 seconds.

The primary trip voltage set point may be adjusted upwards within the range indicated in Table 1 and still comply with UL1741.

The primary duration to trip may also be adjusted downwards as indicated in Table 1 and still comply with UL1741.

### **Fast Under Voltage Trip**

The Fast Under Voltage is adjustable from  $0 V_{L-L}$  up to the Under Voltage set point. (Default = 264V). The time period is adjustable from 0.03 to 1.000 second in 0.001 second increments. (Default = 0.095 seconds)

The UL1741 requirement for this function is:

- *The device should cease to energize the output within 6 cycles when any of the phase voltages is lower than  $139 V_{L-N}$  while the other phase voltages remain at  $277 V_{L-N}$*

As shipped, each Power Controller is tested to verify that it meets the UL1741 requirement to cease power export to the grid within 100 ms if the voltage drops to  $139 V_{L-N}$ . If the grid voltage re-stabilizes to a level between the Primary Under Voltage Trip and the Primary Over Voltage Trip levels within 1.0 second of the initial Fast Under Voltage event, then the Power Controller will resume power export to the grid, otherwise a Grid Fault Shutdown is initiated.

The Fast Under Voltage Trip level may be adjusted upwards as indicated in Table 1 and still complies with UL1741. The duration to the Fast Under Voltage Trip may also be adjusted downwards as indicated in Table 1 and still comply with UL1741.

The Under Voltage protective functions are illustrated in Figure 3. The under voltage trips are programmed into the Power Controller as phase-to-phase voltages.

Voltages indicated in Figure 3 are phase-to-phase voltages. However, the actual trip functions are based on phase-to-neutral voltages with equivalent trip levels.

**Table 1. Under Voltage Protective Function Parameters**

Display Mode	Parameter Description	Parameter Value	Default	RS-232 Command
Grid Connect Menu				
Under Voltage	If the voltage on any phase falls below this setting for greater than Under Voltage Time, the system will shut down.	360 to Over Voltage (L-L)	428	UNDVLT
Under Voltage Time	Establishes the time period allowed for any phase voltage to fall below the Under Voltage limit.	0.3 to 10 seconds	1.90	UVLTTM
Fast Under Voltage	The system will cease to export power to the grid within 1 msec if any phase voltage drops below this voltage for greater than Fast Under Voltage Time.	0 to Under Voltage (L-L)	264	FSTUVL
Fast Under Voltage Time	Establishes the time period allowed for any phase voltage to fall below the Fast Under Voltage limit.	0.03 to 1.000 seconds	0.095	UVFSTM

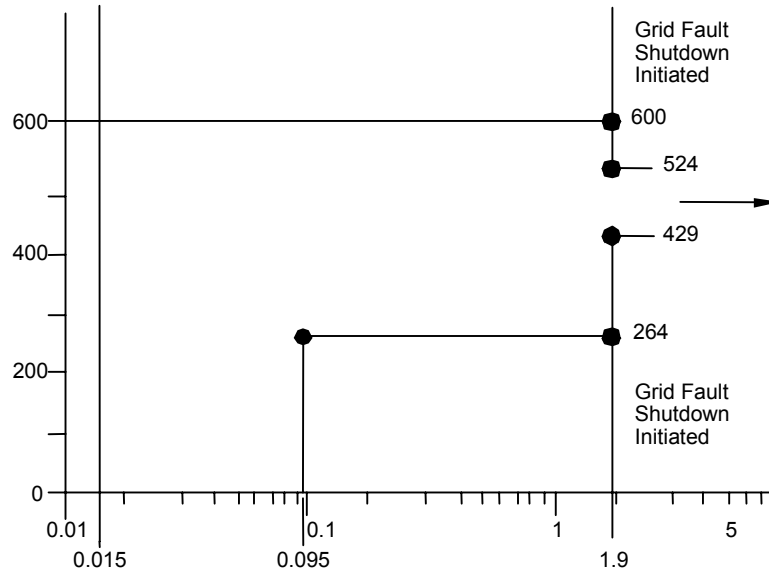

Figure 3. Grid Fault Shut down Trip Limits for Over/Under Voltage Events

## Over Voltage (Protective Function 59)

### Primary Over Voltage Trip

The Primary Over Voltage is adjustable from 528  $V_{L-L}$  down to the Under Voltage set point. (Default = 524V). The time period is adjustable from 0.3 to 10.00 seconds in 0.01 second increments. (Default = 1.90 seconds)

The UL1741 requirement for this function is:

- *The device should cease to energize the output within 2 seconds when any of the phase voltages is higher than 305  $V_{L-N}$  while the other phase voltages remain at 277  $V_{L-N}$*

As shipped, each Power Controller is tested to verify that it meets the UL1741 requirement to initiate a *Grid Fault Shutdown* if any phase voltage swells to greater than 305  $V_{L-N}$  for duration greater than 2.0 seconds. The primary trip voltage set point may be adjusted downwards within the range indicated in Table 2 and still comply with UL1741. The primary duration to trip may also be adjusted downwards as indicated in Table 2 and still comply with UL1741.

### Fast Over Voltage Trip

The Fast Over Voltage is adjustable from the Over Voltage up to 634 Volts. (Default = 600V). The time period is adjustable from 0.03 to 1.000 second in 0.001 second increments. (Default = 0.032 seconds)

The UL1741 requirement for this function is:

- The *device* should cease to energize the output within 2 cycles when any of the phase voltages is higher than  $374 V_{L-N}$  while the other phase voltages remain at  $277 V_{L-N}$

As shipped, each Power Controller is tested to verify that it meets the UL1741 requirement to cease power export to the grid within 33 ms if any phase voltage swells to  $374 V_{L-N}$ . If the grid voltage re-stabilizes to a level between the Primary Under Voltage trip and the Primary Over Voltage Trip levels within 1.0 second of the initial Fast Over Voltage event, then the Power Controller will resume power export to the grid, otherwise a Grid Fault Shutdown is initiated.

The Fast Over Voltage Trip level may be adjusted downwards as indicated in Table 2 and still comply with UL1741. The duration to Fast Over Voltage Trip may also be adjusted downwards as indicated in Table 2 and still comply with UL1741.

These Over Voltage protective functions are illustrated in Figure 3. The over voltage trips are programmed into the Power Controller as phase-to-phase voltages. Voltages indicated in Figure 3 are phase-to-phase voltages. However, the actual trip functions are based on phase-to-neutral voltages with equivalent trip levels.

**Table 2. Over Voltage Protective Function Parameters**

Display Mode	Parameter Description	Parameter Value	Default	RS-232 Command
Grid Connect Menu				
Over Voltage	If the voltage on any phase rises above this setting for greater than Over Voltage Time, the system will shut down.	Under Voltage to 528 V (L-L)	524	OVRVLT
Over Voltage Time	Establishes the time period allowed for any phase voltage to rise above the Over Voltage limit.	0.3 to 10 seconds	1.90	OVLTTM
Fast Over Voltage	The system will cease to export power to the grid within 1 msec if any phase voltage rises above this voltage for greater than Fast Over Voltage Time.	Over Voltage to 634 V (L-L)	600	FSTOVL
Fast Over Voltage Time	Establishes the time period allowed for any phase voltage to rise above the Fast Over Voltage limit.	0.03 to 1.000 seconds	0.032	OVFSTM

## Over/Under Frequency (Protective Function 81 O/U)

The Over Frequency is adjustable from Under Frequency to 65 Hz; in 0.1 Hz increments (Default = 60.5 Hz). The time period is adjustable from 0.06 to 10.00 seconds in 0.01 second increments (Default = 0.09 seconds)

The UL1741 requirement for Over Frequency function is:

- ❑ *The device should cease to energize the output within 6 cycles when the grid frequency is higher than 60.5 Hz.*

The Under Frequency is adjustable from 45 Hz to Over Frequency, in 0.1 Hz increments. (Default = 59.3 Hz). The time period is adjustable from 0.06 to 10.00 seconds in 0.01 second increments. (Default = 0.09 seconds)

The UL1741 requirement for Under Frequency function is:

- ❑ *The device should cease to energize the output within 6 cycles when the grid frequency is lower than 59.3 Hz.*
- ❑ As shipped, each Power Controller is tested to verify that it meets the UL1741 requirement to initiate a Grid Fault Shutdown, if the line frequency is greater than 60.5 Hz or is less than 59.3 Hz for a duration of 100 ms.

The Over Frequency trip limit may be adjusted downwards as indicated in Table 3 and still comply with UL1741.

The Under Frequency trip limit may be adjusted upwards as indicated in Table 3 and still comply with UL1741.

The duration to trip may also be adjusted downwards as indicated in Table 3 and still comply with UL1741.

## **Rate of Change of Frequency (Anti-Islanding Protective Function)**

The Power Controller contains integrated active anti-islanding protective functions. These include an excessive Rate of Change of Frequency protective function, which will cause a Grid Fault Shutdown. The anti-islanding protection is tested and verified as part of the UL1741 listing.

**Table 3. Over/Under Frequency Protective Function Parameters**

Display Mode	Parameter Description	Parameter Value	Default	RS-232 Command
Grid Connect Menu				
Under Frequency	If the grid frequency falls below this value for greater than Under Frequency Time, the system will shut down	45 Hz to Over Frequency	59.3	UNDFRQ
Under Frequency Time	Establishes the time period allowed for the Frequency to fall below the Under Frequency limit.	0.06 to 10 seconds	0.09	UFRQTM
Over Frequency	If the grid frequency rises above this value for greater than Over Frequency Time, the system will shut down	Under Frequency to 65 Hz	60.5	OVRFRQ
Over Frequency Time	Establishes the time period allowed for the Frequency to rise above the Over Frequency limit.	0.06 to 10 seconds	0.09	OFRQTM

## Over Current and Fault Current

In the Grid Connect mode, the total fault current capacity at the installation site is the sum of the fault current from the electric utility grid and that produced by all the on-site generators, including MicroTurbines. At most installation sites the addition of a Capstone MicroTurbine may not result in a significant increase in the total fault current. However, the potential impact of the increase in fault current should be assessed.

The rating of fault current interrupting *devices* at the site should be checked to ensure that they are capable of interrupting the total fault current available. The electric utility grid operator will usually wish to be informed of the MicroTurbine fault current contribution in order to assess the impact of the additional fault current on the electric utility grid and customers connected to it.

When operating in Grid Connect mode, the Power Controller operation is controlled to deliver current corresponding to the power delivery set point (but always less than the output current limit of 46 A for the Model C30, or 100 A for the Model C60). This is the maximum continuous RMS current that will be delivered from the Power Controller under all circumstances, regardless of conditions on the grid.

The maximum phase current is limited to 58 A in any 1/2 cycle for the Model C30, or 125 A in any 1/2 cycle for the Model C60, by current control and hardware trips internal to the solid state power converters. The over-current trips operate within approximately one microsecond ( $\mu$ s), and current decays to zero within approximately one millisecond (ms).

This represents the maximum transient fault current and the maximum duration that this fault current could flow through the output of the Power Controller to the grid.

Note that it is essential for safe operation and service that a current limiting disconnect device (breaker or fused disconnect) be installed between the Power Controller and the

utility grid. The disconnect device must be rated for the total fault current. Local electric codes will almost always require such a disconnect. The added protection of this disconnect device is not considered here.

## **Reverse Power Flow (Protective Function 32)**

The Power Controller may be programmed to initiate a *Normal Shutdown* upon detection of reverse power flow at a remote location by installing a pulse-issuing power meter at a remote location between the utility service entrance and the point where the MicroTurbine is connected. Detailed requirements for this installation are described in the Grid Connect Operation Technical Reference (410027).

As shipped, the Reverse Power Protective function in the Power Controller is not enabled. It may be enabled at installation. When enabled, the Reverse Power Flow Protective function will initiate a *Normal Shutdown* when reverse power flow is measured for a duration of 120 seconds. This duration may be adjusted downwards to 0 second.

Note that a duration of 0 second cannot be realistically achieved. The minimum duration depends on the kWh per pulse calibration factor of the power meter and the magnitude of the reverse power flow. In practice, if the duration is set as 0 second, the shutdown will be initiated when the first reverse power flow pulse is received.

Alternatively, a reverse power flow relay may be interfaced with the external fault inputs to initiate a Grid Fault Shutdown when reverse power flow is detected.

## **Shutdown**

When one or more of the protective relay functions initiates a Grid Fault Shutdown, the following events occur:

- ❑ Output power flow ceases within 1.0 ms
- ❑ The Power Controller contactor (Figure 2) is opened within 100 ms
- ❑ Fuel flow to the turbogenerator stop

A warm shutdown ensues during which control power is supplied from the MicroTurbine generator as it slows down. The warm-down lasts 1-2 minutes before the rotor is stopped. The control software provides for an optional automatic restart when grid voltage and frequency are within permitted limits for a programmable period of time (up to 60 minutes).

When a *Normal Shutdown* is initiated by the Reverse Power Flow Function, the following events occur:

- ❑ Fuel flow to the turbogenerator stops
- ❑ A cool-down of the engine takes place lasting up to 10 minutes for the Model C30, and up to five minutes for the Model C60. (During cool-down, the grid power is used to motor the engine.)
- ❑ Output power flow ceases within 1.0 ms
- ❑ The Power Controller contactor (Figure 2) is opened within 100 ms

## Capstone Technical Support

If questions arise regarding Protective Relay Functions for your Capstone MicroTurbine, please contact Capstone Turbine Technical Support for assistance and information.

### Capstone Technical Support

Toll Free Telephone: (877) 282-8966

Service Telephone: (818) 407-3600 • Fax: (818) 734-1080

E-mail: [service@capstoneturbine.com](mailto:service@capstoneturbine.com)

### Capstone Technical Support (Japan)

Service Telephone: (818) 407-3700 • Fax: (818) 734-1080

E-mail: [servicejapan@capstoneturbine.com](mailto:servicejapan@capstoneturbine.com)

### Capstone Turbine Corporation

21211 Nordhoff Street • Chatsworth, CA 91311 • USA

Telephone: (818) 734-5300 • Fax: (818) 734-5320

Website: [www.microturbine.com](http://www.microturbine.com)